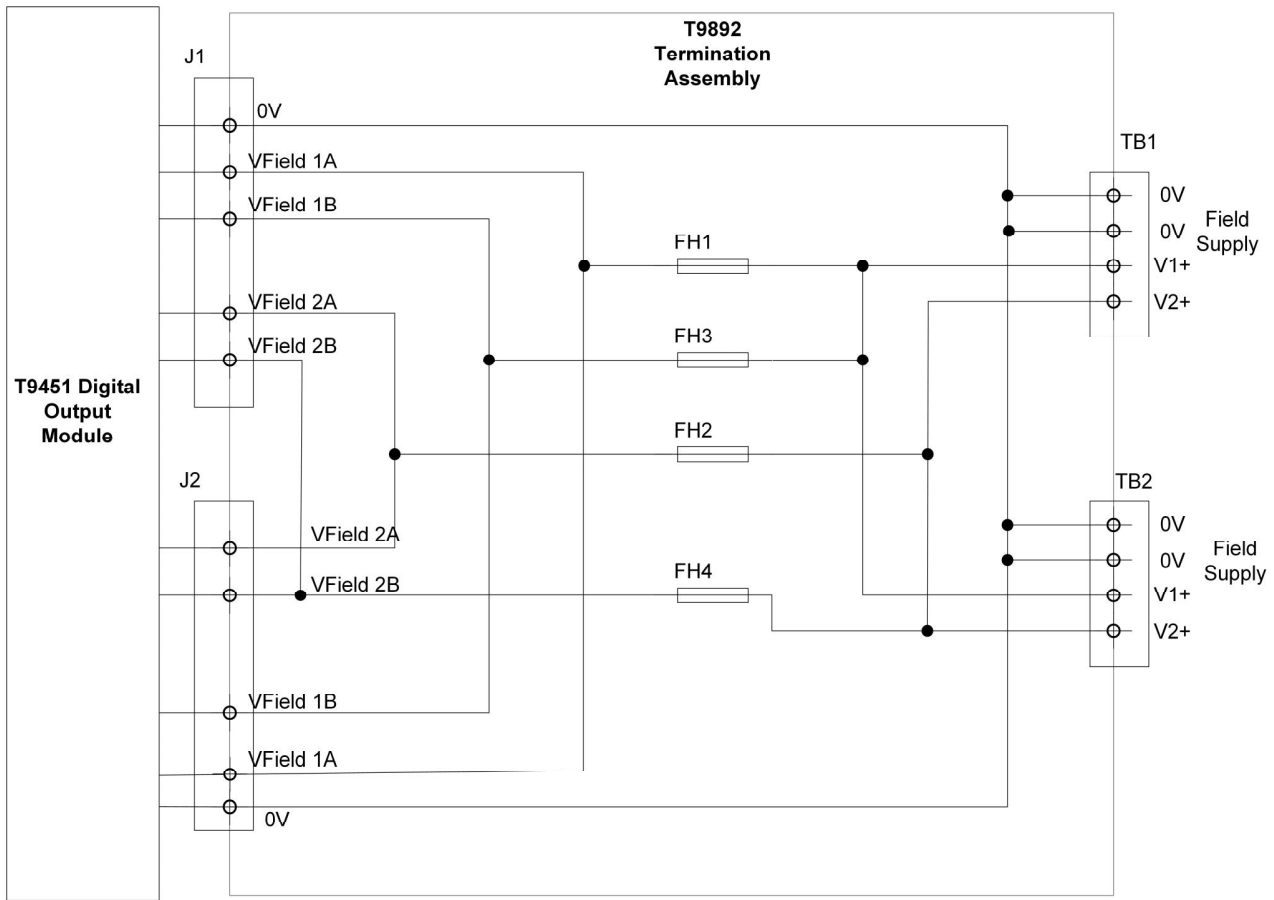

Figure 34 - Schematic T9882



T9481/2 Analogue Output Module

The T9481 and 9482 analogue output modules deliver 4 mA to 20 mA output current for field devices. Each channel is a current sink device and in simplex mode a channel drops the full demanded current. In dual module operation each channel drops half the output current.

The module features voltage and load current channel monitoring, reverse current protection and short and open circuit line monitoring. It is designed to always be able to switch off an output when demanded.

Internal diagnostics do continuous functionality checks. All module, channel and status information is displayed on front panel indicators and status data is routed to the AADvance where it can be viewed and checked. The module has a user configurable failure mode that can be set outputs to hold last state, fail safe, or a user specified output state. In dual mode the two modules communicate with each other by an inter-module link to maintain fault tolerant operation'.

This module supports HART commands #03 to collect data from the field device. The application can be configured to use HART information to monitor and respond to device conditions. It may also be used to supply diagnostic information such as comparison and error reporting.

T9481/2 Analogue Output Module Specification

Table 33 - Analogue Output Module Specification

Attribute	Value
Functional Characteristics	
Output channels	T9481: 3 T9482: 8
Performance Characteristics	
Safety integrity level	
Safety level degradation	1oo1D, 1oo2D
Safety accuracy	200 μ A
Self-test interval	< 1 hour, system dependent
Value of least significant bit (control)	0.98 μ A
Value of least significant bit (monitor)	3.9 μ A
Error at 25 °C \pm 2 °C	
After 1 year at 40 °C	0.30 % + 10 μ A
After 2 years at 40 °C	0.35 % + 10 μ A
After 5 years at 40 °C	0.44 % + 10 μ A
Temperature drift	(0.01 % + 0.1 μ A) for each °C
Electrical Characteristics	
Module supply voltage:	
Voltage	Redundant +24 Vdc nominal; 18 Vdc to 32 Vdc range
Module supply power dissipation	3.6 W (12.3 BTU/hr.)
Output voltage:	
Maximum voltage without damage	\pm 60 Vdc
Operating field supply voltage	18 - 32 Vdc
Output current	
Nominal	4 - 20 mA
Maximum range	0.1 - 24 mA
Calibrated accuracy at 25 °C	10 μ A
Output current control resolution	0.98 μ A, 15-bit
Output current control accuracy at 25 °C	\pm 10 μ A
Output current monitoring resolution	3.9 μ A, 13-bit
Compliance voltage	3 Vdc to 32 Vdc
Maximum Compliance voltage slew rate	No limit identified within Compliance voltage range.
Load impedance	
Maximum range	0 - 750 Ω limited by compliance voltage
Typical	250 Ω
Maximum field loop power dissipation	0.77 W for each field loop (2.63BTU/hr.)
Mechanical Specification	
Dimensions (height \times width \times depth)	166 mm \times 42 mm \times 118 mm (6-1/2 in. \times 1-21/32 in. \times 4-21/32 in.)
Weight	290 g (10.5 oz.)
Casing	Plastic, non flammable

T9881/2 Termination Assemblies for Analogue Outputs

T9881 is a simplex 8 channel termination assembly and T882 is the dual termination assembly. Each channel has a capacitor in series with the output.